

Validation of ANSYS Model of Experimental Test Rig Simulating the Flow Inversion in RRs

Sayed Elnaggar ^{a*}

^a *Egyptian Atomic Energy Authority (EAEA), Cairo, Egypt.*

Author's contribution

The sole author designed, analyzed, interpreted and prepared the manuscript.

Article Information

DOI: 10.9734/ACRI/2022/v22i430283

Open Peer Review History:

This journal follows the Advanced Open Peer Review policy. Identity of the Reviewers, Editor(s) and additional Reviewers, peer review comments, different versions of the manuscript, comments of the editors, etc are available here: <https://www.sdiarticle5.com/review-history/87591>

Original Research Article

Received 20 March 2022

Accepted 31 May 2022

Published 02 June 2022

ABSTRACT

The experimental setup was built to simulate the flow inversion in natural circulation loops in research reactors (RRs). In an effort to recognize the buildup of natural circulation in RRs, pool type upward flow after the pump coasts down due to power loss, by Abdel-Latif et al. [1], was investigated. The setup consists of two vertically stacked pipes that simulate the two branches, one of which contains a test section that is composed of electrically heated, corresponding channels that simulate the core. The second one, represents the portion of the coming back pipe that is involved in the growing of core natural circulation. Several experimental tests under various conditions as the branch's initial temperature are performed. The channel's coolant and surface temperatures were monitored. In this study, the thermal-hydraulic (TH) behaviour of the setup is complemented by theoretical analysis using the ANSYS Fluent 17.2 code. The ANSYS Fluent model is validated against the measured values. Typically, the setup is nodalized and a code input is being prepared. The results show that ANSYS Fluent 17.2 qualitatively predicts the thermal hydraulic behaviour and associated flow inversion phenomenon of such facilities. There is a difference between the predicted and measured values, especially for the channel's surface temperature.

Keywords: Research reactors; parallel channel; ansys fluent; natural circulation; flow inversion.

1. INTRODUCTION

"The safety objectives of the research reactors include adequate margins against critical

phenomena being investigated. When the necessary margins are tested, such as critical heat flux, flow instability, and flow inversion, natural circulation in parallel channels with

*Corresponding author: Email: sayed_elnaggar@yahoo.com;

different heat inputs was developed experimentally and analytically” by Takeda et al. [2] in 1987.

A flow rate and direction have been obtained in each channel depends on the time history of the channel temperature. It was found that the flow rate and direction in many parallel channels are affected by the addition of weak forced circulation.

An analytical model has been predicted for the natural circulation of the flow, including the reversal. Chang and Stan [3] in 1993 carried out an experimentally steady state CHF for conditions simulating natural convection conditions in a vertical rectangular flow channel with an L/D ratio of 154 for both upward and downward flow.

Ouyang and Yang [4] in 1994 investigated “the capability of natural circulation cooling of reactors following a loss of cooling accident using a test facility”.

A vertical heated tube and an unheated by pass channel were used with initial up flow and down flow conditions. Both experimental results and RELAP5 have been compared. A transient phenomenon, from forced convection through flow reversal into natural circulation cooling, has been observed. The analytical results have shown that a natural circulation cooling pattern can be established and that a significant cooling period can be maintained for both the initial up flow and the initial down flow conditions.

The RELAP5 simulation predicts the transient phenomena from forced convection into natural circulation cooling very well. Both the initial flow direction and the coast down rate have effects on the development. The two-phase natural circulation cooling limit is higher for the test that starts with upflow forced convection than for the tests with initial down flow.

In addition, the natural cooling circuit (NCC) developed from an initial down flow system is subject to greater flow oscillation than that developed from an initial up flow system. The pump coast down is identified as a significant factor in the establishment of natural circulation from an initially forced flow condition. The effect of pump coast down is also dependent on the initial flow direction. In the case of vertical down flow, the results from the RELAP5 simulation clearly demonstrated a strong effect of the speed

of flow coast down on the establishment of natural circulation cooling.

The simulation results showed that for an initial vertical down flow, the faster the flow coasts down, the easier it is for the development of natural circulation cooling. For the test with initial upflow force convection, the effect of pump coast down rate is not significant.

Abe et al. [5] in 1994 studied experimentally and analytically the fundamental two-phase flow behaviour under natural circulation conditions. The focusing of the flow patterns has been investigated experimentally. flow rate and two-phase behaviour inside the vessel. The natural circulation characteristics have been performed analytically. Both experimental and analytical results confirmed that sufficient and stable flow can be achieved in a BWR natural circulation system.

Khattab and Mina [6] in 1999 analyzed “research reactor core thermal-hydraulics using rod and plate types of fuel elements without altering the core bundles' square grid spacer (68 mm on side). Reactor power could be upgraded from 2 to 10 MW without significantly altering the steady state, thermal-hydraulic safety margins. Fuel, clad, and coolant transient temperatures are determined inside the core hot channel during flow coast down using the PARET code”.

Housiadas [7] in 2000 “simulated numerically the course of loss-of-flow transients in pool-type research reactors, with scram disabled. The analysis with a customized version was performed with the code PARET. Two-phase flow stability boundaries have been determined as a function of initial reactor conditions. The author recognized that flow instability is the basic mechanism responsible for core damage in such types of transients. A useful chart describing the stability region in terms of initial reactor power, initial pool temperature, peaking factor, and flow-decay time constant, has been provided”.

Wang and Vafai [8] (2000) have investigated “experimentally and analytically the thermal performance of a flat-plate pipe during startup and shut down operations. An analytical model developed has been used in a previous study. They have presented the effect of input power and cooling on the thermal performance of the heat pipe. The main objective of the present work is to investigate experimentally the thermal hydraulic transient behaviour of the MTR pool

type upward flow at the later stage of pump coast down, which follows the reactor scram due to the loss of power. The study aims to clarify the effect of the reactor pool temperature”.

Meng et al. [9] presented “the phenomena of instabilities in a natural circulation system with 4 parallel heated channels that were simulated and analyzed by using the RELAP5 code. The results showed that there were 3 different types of instabilities dominated by sub-cooled boiling, flashing, and saturated boiling, respectively, and the mechanisms were interpreted”.

2. METHODOLOGY

2.1 A Summary of the Experimental Work

The flow inversion has been studied experimentally with a test rig, as shown in the schematic diagram in Fig. 1 and the photograph in Fig. 2. It was designed in reference to [1]. It was selected as the research object, and it's geometric. This test rig consists of a vertically oriented test section (1) that contains two electrically heated channels extended between upper and lower plenums (2&3). The upper plenum (3) is connected to a cold water tank (4)

through a vertical pipe (15). The water temperature in the tank (4) is changed through a cooling circuit (8). The lower plenum (2) of the test section is connected to the hot water tank (5) through a vertical pipe (9) simulating the core return pipe. An electrical heater (6) is inserted into the tank (5) to change its temperature. To establish a closed cooling loop, the two tanks are connected through a ball valve (7). Many copper-constantan thermocouples are calibrated and axially disturbed on the coolant channels and their heating walls. The buildup of natural convection in the above experimental setup is assumed to be governed by three key parameters; the channel power, the initial left and right column temperatures.

Therefore, three groups of experimental runs are performed. In each group, only one of the key parameters is changed. One of these experimental groups is used in the present study for ANSYS Fluent 17.2 code validation. This group consists of four runs at left column temperatures of 283, 293, 303, and 313K. Other important parameters include a constant at; channel powers of 1000 and 500Watts; and a right column temperature of 323K.

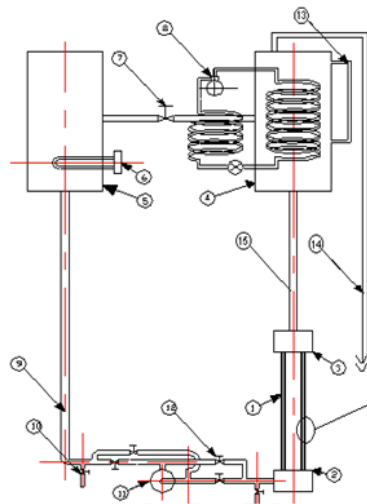

- | | |
|-----------------------------|------------------------|
| 1- Test section | 9- Hot vertical pipe |
| 2- Lower plenum | 10- Drain |
| 3- Upper plenum | 11- Pump |
| 4- Cold tank (pool) | 12- Valve |
| 5- Hot tank (inlet channel) | 13- Water indicator |
| 6- Electric heater | 14- Water supply |
| 7- Valve | 15- Cold vertical pipe |
| 8- Cooling circuit | |

Fig. 1. Schematic diagram of the experimental test rig [1]



Fig. 2. Photograph of the Experimental setup

2.2 Error in Determining the Temperature Difference

The temperature difference is measured by pre-calibrated copper-constantan thermocouples. The data acquisition system receives the output signals of these thermocouples. The minimum accurate readable value is 0.1 °C,

$$\text{hence } \left| \delta(\Delta \bar{T}_s) \right|_m = \frac{0.1 \times 100}{5.86} = 1.7065\%$$

3. ANSYS FLUENT 17.2 MODEL

3.1 Description of ANSYS Fluent 17.2 Computational Model

In order to model the natural circulation, the governing equations were solved using a finite volume method. The ANSYS Fluent 17.2 code [10] is used for numerical simulations. The numerical simulation exactly mirrors the experiment. The experiment is modelled with 3D-structural elements. The model consists of two vertically oriented branches, one of which contains two rectangular, electrically heated, parallel channels that simulate the core. The other branch represents the portion of the return pipe that is involved in the development of core natural circulation as shown in figure (3).

The theoretical predictions are validated with the experimental measurements. The mesh resolution as shown in table 1 (Mesh Report), this

is in line with ANSYS best practice guidelines for modeling natural convection flows as shown in Fig. (3).

3.2 Flow Governing Equations used in CFD Modeling

The CFD flow solver based on finite volume method is used in the present work to solve Reynolds Averaged Navier–Stokes (RANS) equations and species transport. The flow is assumed as steady and incompressible. The conservation equations of continuity, momentum and energy can be represent as follow [7]:

Continuity equation:

$$\frac{\partial U_i}{\partial x_i} = 0 \quad (1)$$

Momentum equation:

$$\rho U_i \frac{\partial U_i}{\partial x_i} = -\frac{\partial P}{\partial x_j} + \frac{\partial}{\partial x_i} \left[\mu \left(\frac{\partial U_i}{\partial x_j} + \frac{\partial U_j}{\partial x_i} \right) - \rho \overline{u_i' u_j'} \right] \quad (2)$$

Energy equation:

$$\rho C_p U_i \frac{\partial T}{\partial x_i} = \frac{\partial T}{\partial x_j} \left[\lambda \frac{\partial T}{\partial x_j} - \rho C_p \overline{u_i' T_i'} \right] + S_h \quad (3)$$

The Realizable κ - ϵ model was used in the present CFD work.

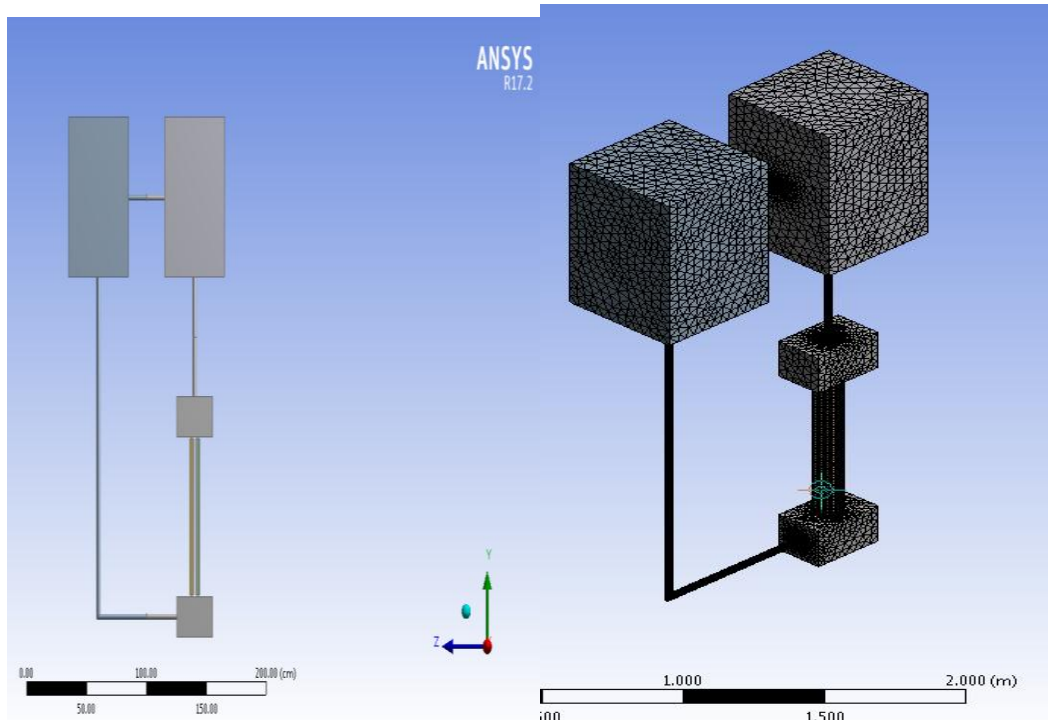

Fig. 3. Experimental setup ANSYS Model and Mesh of ANSYS Model

Table 1. Mesh Report

Domain	Nodes	Elements
cold leg	11486	55789
heater1 2	2612	1146
heater3 4	2642	1161
hot leg	31508	146623
main	14271	62142
All Domains	62519	266861

4. RESULTS AND DISCUSSIONS

4.1 The First Section Displays the Graph of the Results Obtained from ANSYS Model

Figure (4) represents the field of temperature at the start of the developed model to show the initial conditions. Figure (5) shows the variation of the temperature through the two channels, the flow outlet from the top of the high power channel is remarked, where the flow outlet from low power channel at the bottom the results presented herconsisting of twosections.

Fig. (6) represents the variation of velocity stream Lines in the two channels. From this distribution of the stream lines ; out from high power channel

(left side) and inlet to low power channel (right side). The flow reveals in low power channel is conducted.

4.2 Validation of the ANSYS FLUENT 17.2 model

Validation analysis has been performed over the studied range of pool temperatures (283-313K) in order to confirm the accuracy of the model. To do this, the data (coolant temperature) calculated by ANSYS model were compared to the measured data. Figure 8 depicts the compared inlet and outlet channel coolant temperatures at a constant power ratio =1/2. The comparisons show the good agreement between the code outputs and experimental data.

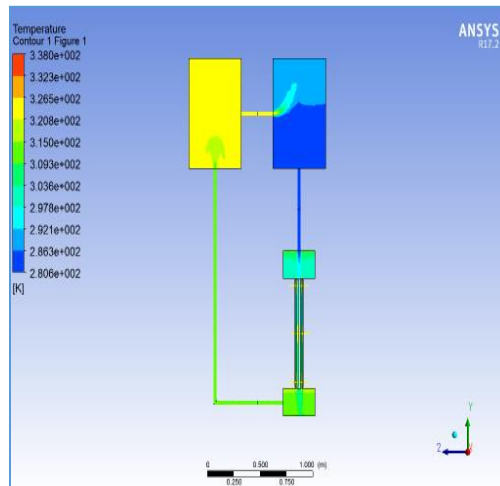

Fig. 4. Temperature fields, of ANSYS Test RigModel

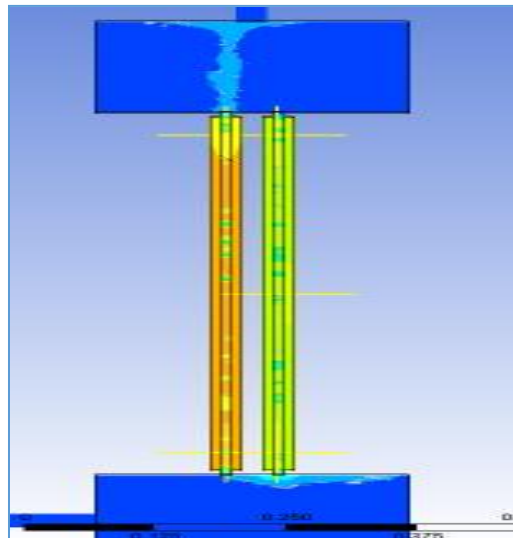

Fig. 5. Contour of the temperature test section

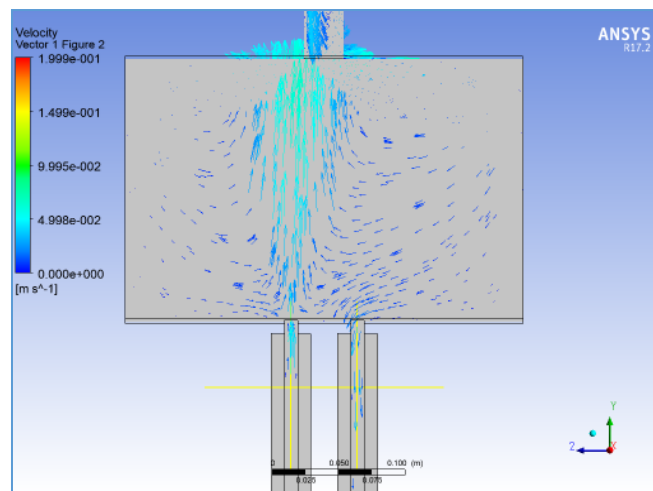

Fig. 6. Instantaneous velocity stream Lines

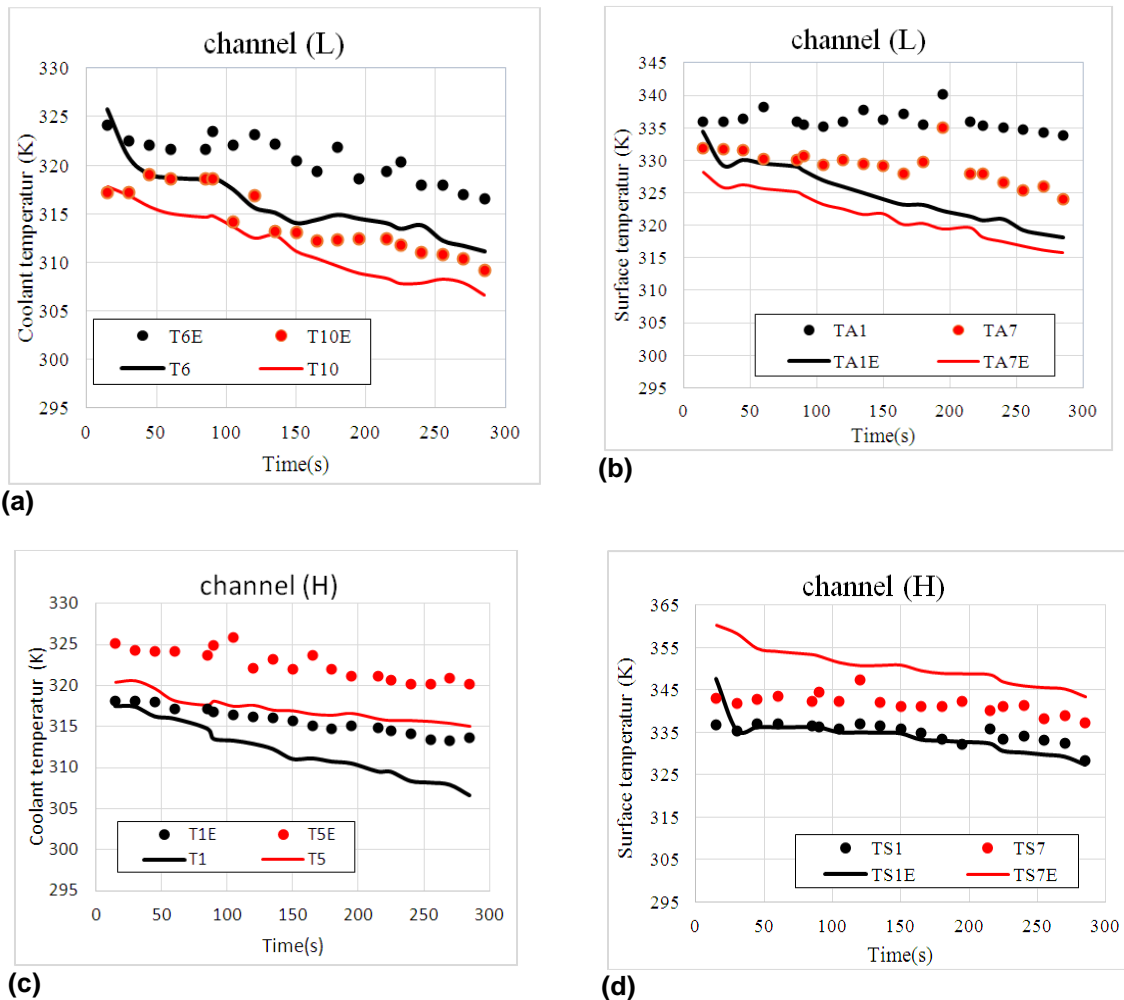

Fig. 7. Shows a comparison of experimental and ANSYS results for coolant and surface temperatures at the inlet and outlet of high and low power channels for right column temperature. $T_r=283K$

4.2.1 Comparison between experimental measurements and calculated (ANSYS Model results)

Figures (7) and (8) show the channel coolant and surface temperatures at their lower and upper ends for right column temperatures (T_r) of 283 and 293 respectively. Generally, there is a difference in the temperature values predicted by ANSYS code continuous lines where (T6 & T10) are the coolant inlet and outlet temperatures for low power channels, respectively. TA1 and TA7 are the surface inlet and outlet temperatures, respectively, for the same channel. The experimental measurements are represented by dots and denoted by (T6E & T10E) and TA1E & TA7E).

In a high power channel, the coolant measurement temperatures are denoted by T1E,

T5E, and the surface inlet and outlet temperatures, respectively. T1E, TS7E. In the ANSYS code, continuous lines where In the high power channel, the coolant temperatures T1, T5 and the surface inlet and outlet temperatures respectively TS1, TS7 are shown in the next figures.

On the other hand, from the coolant temperature, it is obvious that there is an agreement between ANSYS results and experimental measurements. regarding the direction of the flow and downward flow in the low power channel (L) and upward flow in the high power channel (H), where the coolant temperature at the lower end is higher than that at the upper end of (L) and vice versa in (H). Also, the deviation between ANSYS results and experimental measurements decreased with increasing the right column temperature T_r as shown in Fig. (8).

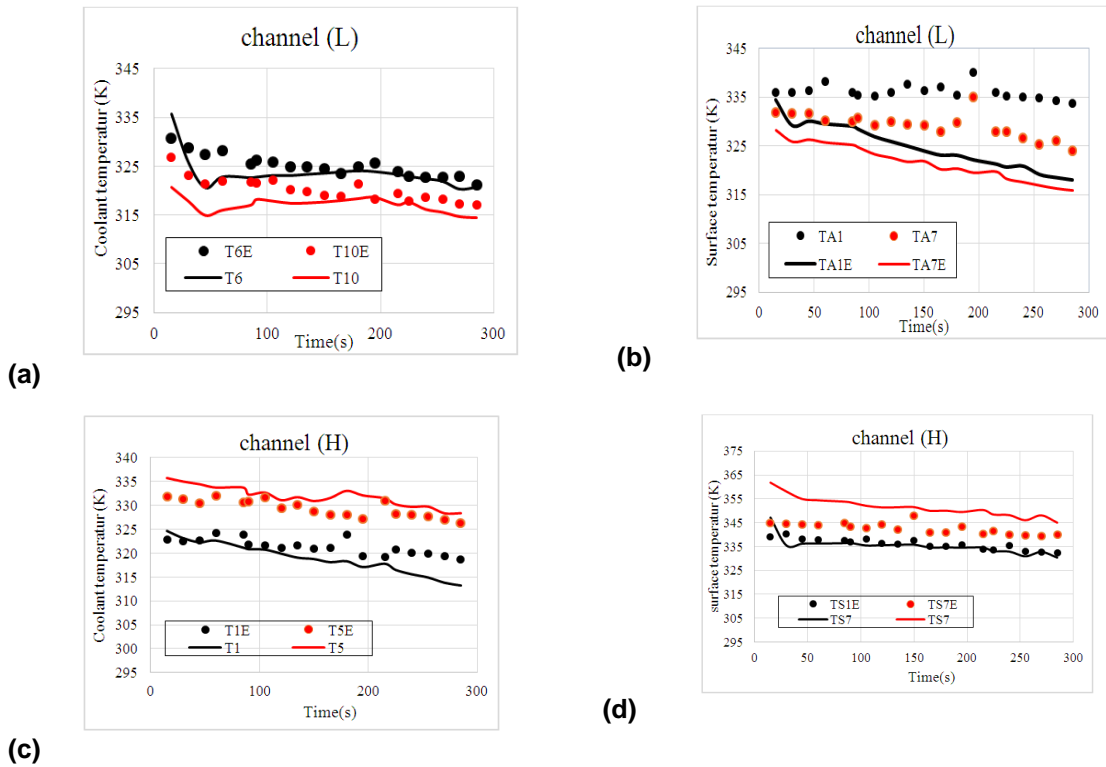

Fig. 8. Comparison between experimental measurements and ANSYS results of coolant and surface temperatures at the inlet and outlet of high and low power channels for right column temperature $T_r=293K$

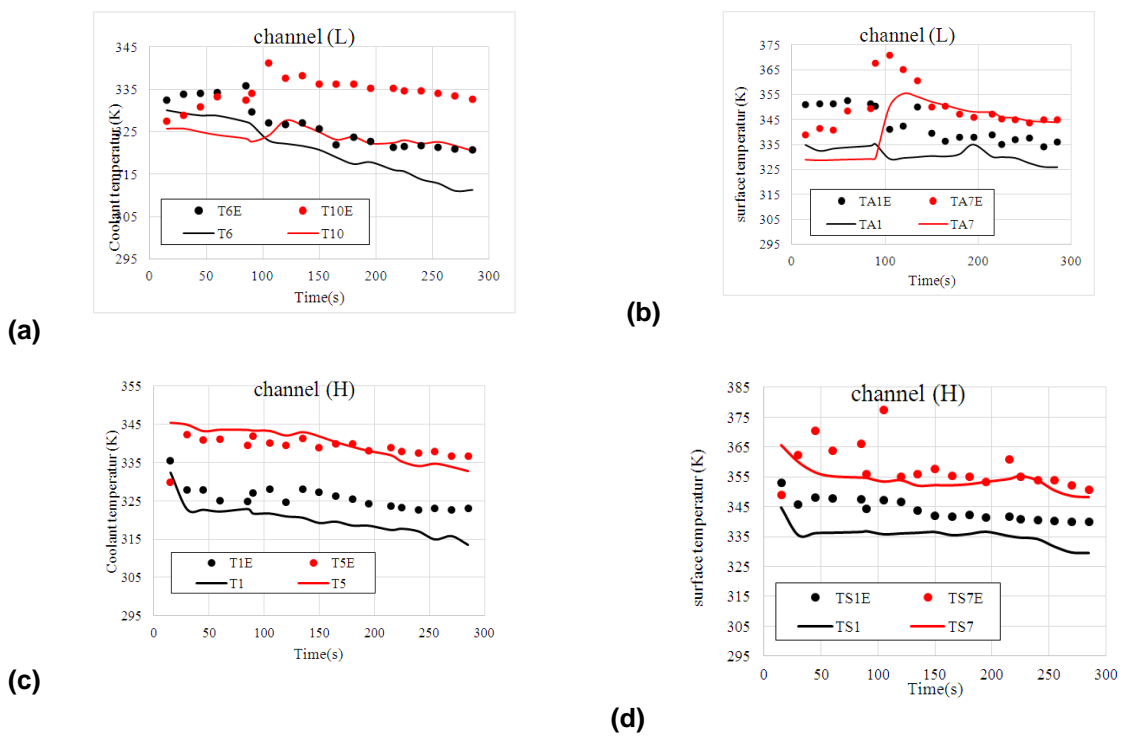

Fig. 9. Comparison between experimental measurements and ANSYS results of coolant and surface temperatures at inlet and outlet of high and low power channels for right column temperature $T_r=303K$

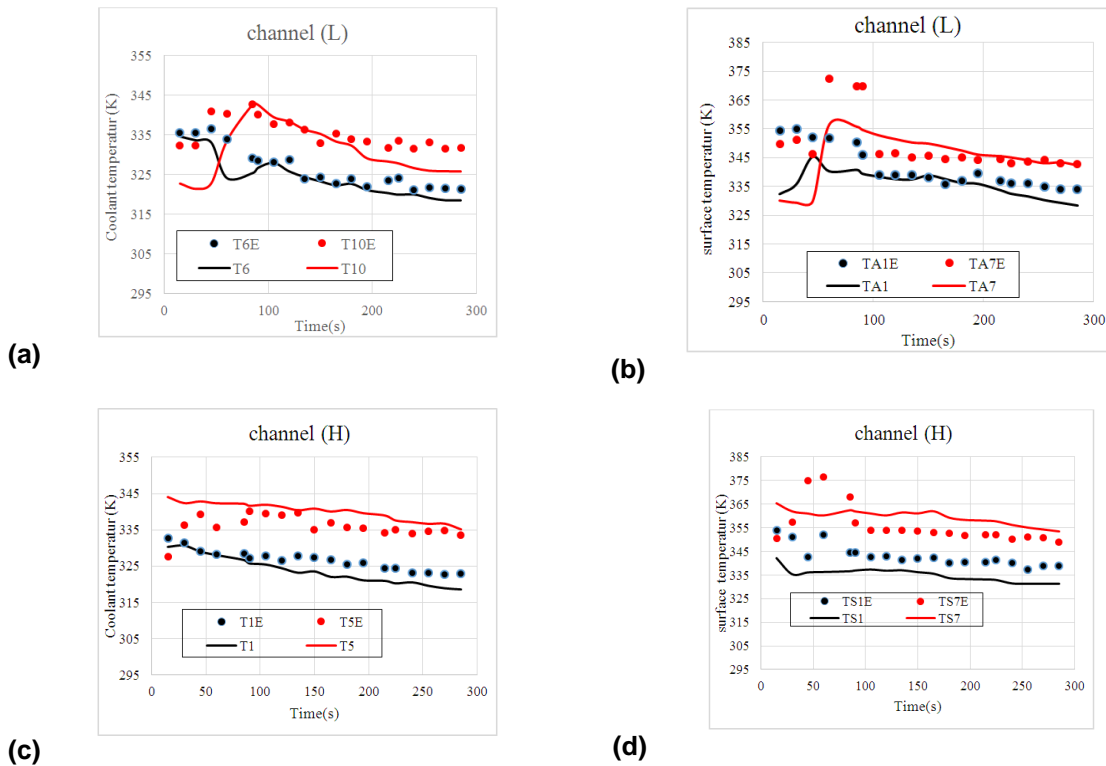

Fig. 10. Shows a comparison of experimental and ANSYS results for coolant and surface temperatures at the inlet and outlet of high and low power channels for right column temperature. $T_r=313K$

4.2.2 Comparison between experimental measurements and calculated (ANSYS Model results)

Fig. (9) shows the comparison at a right-column temperature of 303 K. There are three observations on the results. Firstly, the ANSYS model predicts the occurrence of flow inversion in the channel (L) from downward to upward, in agreement with the experimental measurements. The inversion appears in the inverse of coolant temperature at the upper and lower ends of the channel (L) as figures (9a) and (9b). Second, despite the disagreement in maximum values, the ANSYS model predicts an increase in coolant and surface temperatures associated with this inversion that is consistent with experimental measurements. may be returned to the form of the heat transfer coefficient in the ANSYS model. Thirdly, the predicted surface temperature in (H) is not affected by the flow inversion in (L), in disagreement with measurement Figs. (9c) and (9d).

Fig. (10) depicts the comparison at the right column temperature of 313 K . The results show

nearly the same qualitative behaviour as that at 303K but with less deviation between the measured and predicted values. The flow inversion in (L) occurs earlier than that at 303K. The effect of flow inversion on the (H), which appears in the measurements as an increase in surface temperature, is not predicted by the ANSYS model.

5. CONCLUSIONS

The experimental investigations showed that; the new design of the core cooling system in MTR research reactors has a great effect on core cooling after pump coast down. After reactor shutdown. The buildup of natural circulation will depend, in addition to the power distribution between the channels, on the temperature difference between the reactor pool and the core return pipe. At low reactor pool temperatures, an inner circulation between the core channels in which an upward flow in the hot channel and a downward flow in the colder channels is established. When the pool temperature approaches the return pipe coolant temperatures, the internal circulation vanishes. The measured temperatures showed an initial

downward flow in the two channels, which represents the first reverse because the simulation here is for an upward flow research reactor. After that, there is a sharp increase in the surface temperature that appears at the occurrence time of the reversal from downward to upward. From a safety standpoint, the most significant side effect of the appearance reversal is the sharp increase in surface temperature. This is the reason beyond the regulatory requirement, which postulates that the design of upward-flow research reactors must avoid the occurrence of reverse flow through the core after reactor shutdown.

DISCLAIMER

The products used for this research are commonly and predominantly use products in our area of research and country. There is absolutely no conflict of interest between the authors and producers of the products because we do not intend to use these products as an avenue for any litigation but for the advancement of knowledge. Also, the research was not funded by the producing company rather it was funded by personal efforts of the authors.

COMPETING INTERESTS

Author has declared that no competing interests exist.

REFERENCES

1. Abdel-Latif SH, Abdel-Hadi EA, Kamal Eldin A, Talha, Khedr A. Experimental Study of Core Cooling after Pump Coast-Down in MTR Pool Type Research Reactor. Ph.D Thesis, Faculty of Engineering at Shoubra, Benha University, Cairo, Egypt; 2014.
2. Takeda T, Kawamura H, Seki M. Natural Circulation in parallel vertical channels with different heat input, Nuclear Engineering and Design. 1987;104:133-143.
3. Chang HOH, Stan BE. Critical Heat Flux for Low Flow Boiling in Vertical Uniformly Heated Thin Rectangular Channels. International Journal of Heat and Mass Transfer. 1993;36(2):325-335.
4. Yang BW, Ouyang W. Dynamics and Developing of Natural Circulation Cooling from Vertical Up flow and down Flow Conditions. The 4th international Topical Meeting on Nuclear thermal hydraulics, operation and safety Columbia University; 1994.
5. Abe N, Yokobori S, Nagasaka H, Tsunoyama S. Two-Phase Flow Natural Circulation Characteristics Inside BWR Vessels. Nuclear Engineering and Design. 1994;146(1-3):253-265.
6. Khattab MS, Mina AR. Core Conversion from Rod to Plate Type Fuel Element in Research Reactors. Arab Journal of Nuclear Sciences and Applications. 1999; 30:247-255.
7. Housiadas C. Simulation of loss-of-flow transients in research reactors. Annals of Nuclear Energy. 2000;27:1683-1693.
8. Wang Y, Vafai K. Experimental Investigation of the Transient Characteristics on a Flat-Plate Heat Pipe during Startup and Shut down Operations. Journal of Heat Transfer. 2000;122(3): 525-535.
9. Meng1 H, zhu1 H, Wang2 T. Study on Flow Instability in Natural Cycle Parallel Channel Based on RELAP5. Experimental Thermal, IOP Conf. Series: Earth and Environmental Science. 2021;770:012-038. DOI:10.1088/1755-1315/770/1/012038.
10. Ansys Fluent 17.2 User's Guide

© 2022 Elnaggar; This is an Open Access article distributed under the terms of the Creative Commons Attribution License (<http://creativecommons.org/licenses/by/4.0>), which permits unrestricted use, distribution, and reproduction in any medium, provided the original work is properly cited.

Peer-review history:
The peer review history for this paper can be accessed here:
<https://www.sdiarticle5.com/review-history/87591>